

8328 MacArthur Dr. • North Little Rock, AR 72118  
501.771.4477 • Fax: 501.771.2333  
Customer Service: 800.255.5766  
E-Mail: tech@jasonhydrotherapy.com  
www.jasonhydrotherapy.com

## Designer Collection Specifications

# KT530-SL/SR

### MicroSilk<sup>®</sup>

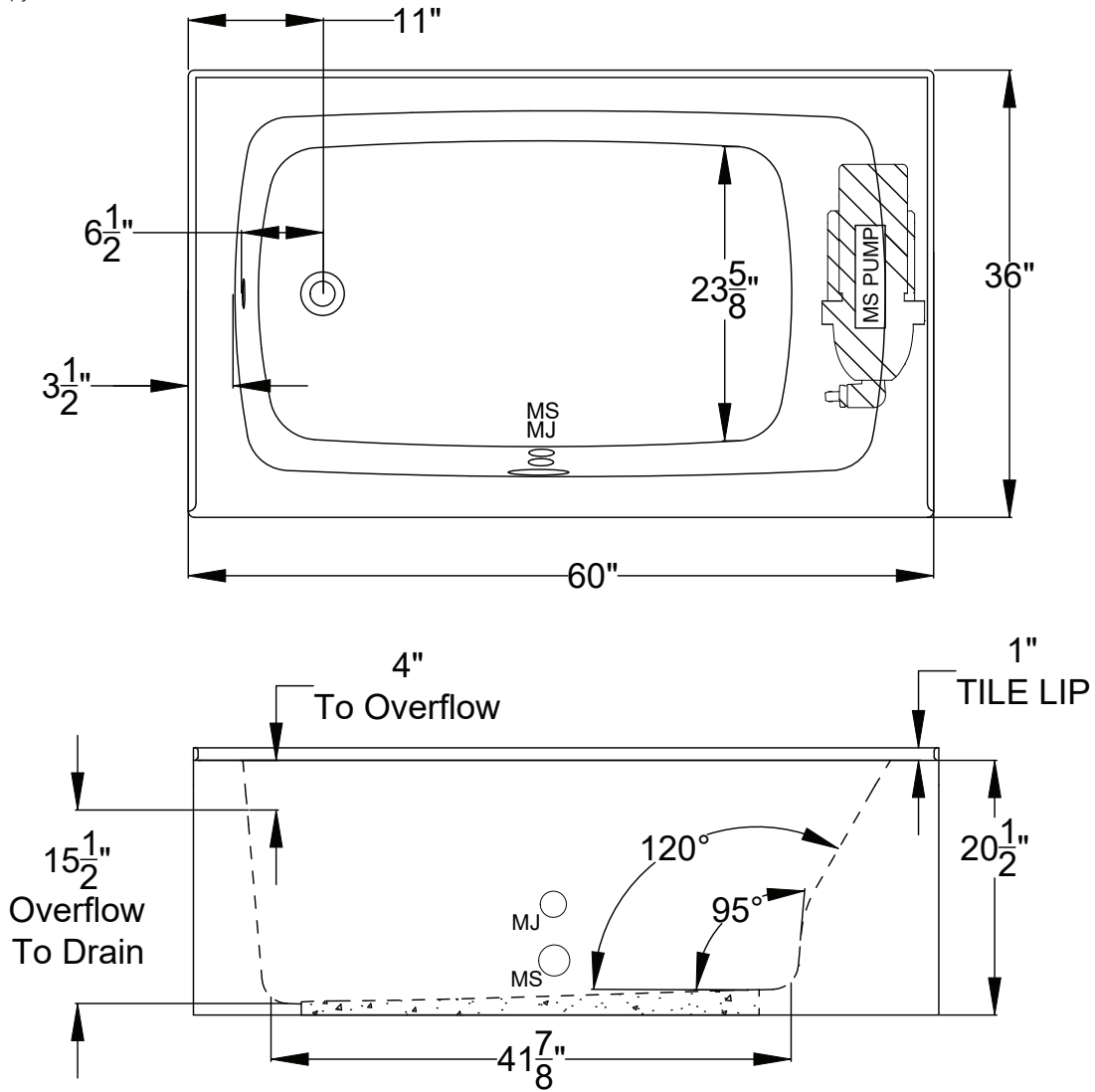



Patents received or pending.

Note: Dimensional Tolerances: ±1/4"

- Drop-in Hole Size:** N/A
- Operating Capacity:** 40 Gal.
- Overflow Capacity:** 66 Gal.
- Floor Loading / sq.ft.:** 50.3 lbs.
- Carton Wt.:** 120 lbs.
- Cube:** 31.3 ft.<sup>3</sup>

**Construction:** Fiberglass reinforced acrylic bath with Level Form™ full-support base.

*We provide products listed with Intertek ETL SEMKO (Edison Testing Laboratories) U.S. and Canadian and with International Association of Plumbing and Mechanical Officials (IAPMO). Consult factory with your listing requirements.*

<b>Standard</b>	 <p>A 120V system that includes a MicroSilk<sup>®</sup> unit, an electronic control, and a 20-minute timer.</p>
<b>Premier</b>	 <p>A 120V system that includes a MicroSilk<sup>®</sup> unit; (2) Chromatherapy mood lights; Automatic Ozone System; a digital control with LCD display, enhanced user control options, and a 20-minute timer. Control keypad controls the MicroSilk<sup>®</sup> unit, LED Chromatherapy mood lights, and shows equipment status, and time remaining.</p>